



AMPS[®]

Advanced Managed Project Services[®]

(800) 998-7800
www.summit.com



The Summit Advantage



Established in 1977, Summit Electric Supply is an independent, privately-held wholesale electrical distributor headquartered in Albuquerque, New Mexico and ranked 20th among the nation's largest electrical distributors. Because we are privately-held, you have direct access to top decision makers. No corporate bureaucracy means increased flexibility and faster decisions.

You will benefit from key logistical advantages that our technical capabilities provide. Our proficiency with internationally recognized enterprise resource planning system SAP is the foundation for advanced materials management.

Many leading electrical manufacturers use SAP as well, such as Thomas & Betts, Sylvania, Eaton and its line of Crouse-Hinds by Eaton and B-Line by Eaton.

Our inventory management capabilities, made possible by a customized program in SAP, give you unparalleled inventory efficiencies.

Our system, combined with forecasting and close communication with onsite personnel, virtually eliminates both surpluses and shortages, saving you significant money in materials handling, warehouse space, and manufacturing time.

Beyond our advanced technology and proven supply systems, Summit's people make the difference. Our knowledgeable and trained team members are equipped to handle your various needs and customize a solution that meets your requirements.

A strategic partnership with Summit Electric Supply offers the technical and logistical capabilities to ensure that the electrical materials so critical to your success will be delivered on schedule – and on budget.

We look forward to providing you with superior technical support and service.



A Commitment to Quality

Summit pursues excellence in meeting the needs of our customers. We continually monitor and improve our performance so we provide the highest levels of support, and we demonstrate that commitment with our registration to the international standard ISO 9001:2008.

Summit was founded in 1977 upon a set of core principles that continue to guide the company today. Summit's quality management system, The Summit Way, defines how we do business and ensures our ability to consistently deliver products and services that meet or exceed our customers' requirements.

We live by this commitment through documented procedures and with a team of some of the most-knowledgeable and best-trained professionals in the industry. The Summit Way encompasses management, performance, and assessment, reflecting how we approach customer service, manage our key processes, share results, and improve associate and company performance.

All Summit locations are registered to the ISO quality standards established by the International Organization for Standardization and each adheres to Summit's commitment to high standards of quality and consistency in our procedures and services.



Supplier Qualification Process

A central part of The Summit Way includes selecting only manufacturers whose products have passed UL testing and product performance in the marketplace. Our primary manufacturers also provide details on their own internal quality assurance programs.

System Solutions

Summit's quality commitment is reflected in our warehousing, inventory, and distribution systems that include:

- Advanced inventory, sales, and order management capabilities
- Vast and broad selection of inventory from leading manufacturers
- Real-time access to available and back-up inventories
- Strong electronic connections to key suppliers
- Well-trained, knowledgeable associates who understand customers' needs

Technical Advantage

Summit has a 20-member, in-house IT department that was recognized in 2010 by the Americas' SAP Users' Group (ASUG) with the group's Impact Award for innovative implementation of SAP. David Wascom, vice president of our IT department, was also recognized for his leadership in the group.

Summit's advanced supply solutions provide better results with a simple methodology for materials management:

- Simple setup
- Simple ordering
- Simple tracking and reporting
- Simple and sensible return policy – if materials are in resalable condition, we'll accept them back.

Our associates are empowered at the local level to meet their customers' needs. Yet they are connected across Summit's entire network. Associates not only see real-time inventory availability, but can also ship product from any Summit location directly to their customer.



SAP gives us greater flexibility to offer custom solutions such as punch-out catalogs, third-party catalog integration, and SAP direct inventory connection. It also provides superior inventory control plus faster, more effective customer service. For each contract agreement, you can be assured of consistent, standardized pricing across Summit's entire network.

Summit is capable of fulfilling site-specific material requirements while offering the newest electrical products and services available that effectively meet each job's specific requirements.



Customized Services



Customized Billing

You can elect to receive invoices daily or one summarized invoice of all individual deliveries over a specified period of time (weekly or monthly) in any format required.

Customer Part Numbers

Summit can load your internal part numbers as a cross reference to Summit's part number. All sales documents can include your part number, along with manufacturer part number and extended description. This helps in receiving and reconciling invoices.

Custom Order Fields

You can request custom fields to be required and captured for each sales order, such as employee number, badge number, or additional purchase information text.

Bar Coding

Summit can print bar-coded item labels for all customer part numbers. We can utilize bar-code technology for all aspects of the material management process, including warehouse shelving, trailer shelving, all appropriate catalogs, and material data sheets. Your copy of delivery receipts, packing labels, summary billings, and any other required documentation can also be bar coded with your

criteria. Summit has a web-based inventory management tool to assist with inventory replenishment.

Kitting/Staging

Summit has the ability to kit and stage material as required. SAP allows us to assign a part number to a group of material, giving managers the ability to view and order, by detail or kit, the complete bill of material for assembly. All kitted and staged items will be clearly tagged and marked with all pertinent information.

Material Take-Off (MTO) Services

Summit utilizes the services of electrical designers and engineers to perform material take-off services. We can perform take-offs by drawing, detail, and unit or area. Drawings will need to be in AutoCad format. Please allow one to two hours per drawing after download to complete take-off. Summit will guarantee a 99% accuracy rate utilizing our services.

Other Services

Summit routinely develops custom solutions to meet the individual needs and requirements of every project. We will work with you to provide the specific services and support needed for any project.

AMPS® - Making Supply Simple



At Summit, we understand building new industrial facilities around the world involves complex challenges. Supply shouldn't be one of them.

That's why we've deliberately simplified materials management while including the critical functions required to provide superior supply chain efficiency.

Summit's Advanced Managed Project Services™ (AMPS®) is a comprehensive menu of supply services that can be customized for individual projects, ensuring the greatest efficiency at the lowest overall cost.

The AMPS program is effective for both domestic and international projects, above one million dollars in value, that require a supplier-managed inventory system that keeps surplus and waste to a minimum.

AMPS encompasses materials sourcing and procurement, competitive project quotations, delivery logistics, real-time inventory tracking, inventory contingency planning, online transaction tracking and customized reporting based on customer requirements.

AMPS helps projects stay on schedule, and on budget, anywhere in the world.

7 Strategic Benefits of AMPS

1. Eliminates long lead times

Purchase and delivery of made-to-order items are actively managed, eliminating extensive lead times.

2. Eliminates down time

Inventory levels set in SAP are matched to work schedules, ensuring adequate supply throughout the duration of project.

3. Avoids both surplus and shortages

Proactive management of on-site inventory virtually eliminates excess material and shortages.

4. Reduces surplus wire and cable

Effective batch management reduces wire and cable surplus to less than 1/2 of 1%.

5. Ensures predictable pricing

Pricing is negotiated prior to the beginning of the project, leveraging Summit's buying power with leading manufacturers.

6. Reduces delivery errors

Each storage location is set up in our system as a specific "ship-to" location for orders, reducing human error in pulling and shipping material.

7. Provides greater transparency and control

Reports based on customer specifications allowing for online transaction tracking, increasing transparency and control in materials procurement.

AMPS® Process

The AMPS® process encompasses six basic steps, each one deliberately simple.



1. Process Action Team

A process action team is established to work with your project managers, attend regular meetings, and coordinate procurement and delivery activities. The purpose of the team is to proactively manage any scheduling or supply changes.



2. Establish Materials List

Summit works with your project managers and engineers to determine an accurate list of materials required for each stage of the project. The materials list forms the basis of the project's electronic catalog, providing for long-lead-time items and minimizing non-stock items. Our central replenishment department ensures required inventory is available and establishes minimum/maximum levels for each item. This initial setup helps establish the most cost-effective inventory plan at the outset of the project.



3. Set Up Storage Location

A storage location is then set up. This may be an onsite manned (or unmanned) job trailer, a separate Summit warehouse, or warehouse space within the customer's facility that is managed by Summit. Setup includes providing all necessary equipment such as forklifts and computers, as well as inventory.

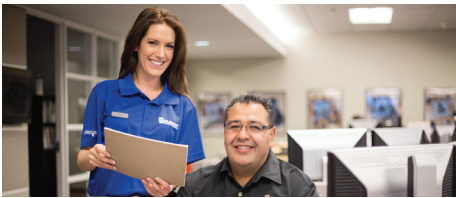

4. Set Up in SAP

The storage location is set up in SAP as a Summit-managed "ship-to" location with its own individual inventory requirements, income and expense records, and transaction records. This results in more accurate ordering and delivering, as well as more specific reporting capabilities.



5. Staging and Release of Materials

Through SAP, materials staging and release is a smooth and simple process. Approved employees can submit orders at the storage location and receive what they need immediately. Managers can also order materials through the electronic project catalog and have them delivered to the job site as needed.

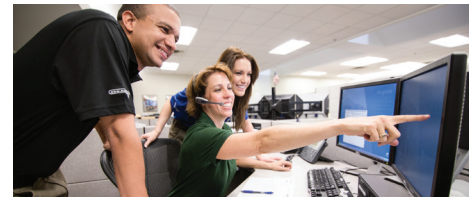

6. Transaction Tracking and Reporting

The process includes continuous transaction tracking and reporting. Summit can provide customized usage reports on a predetermined schedule, or can allow the customer to generate on-demand reports. Project status and tracking is also available through the online AMPS Portal.

Summit OnSite®



Summit provides comprehensive solutions for all of your onsite needs. Summit OnSite® – or SOS® – offers customizable mobile storage for your job site, the ability to set up Summit-manned or customer-manned facilities, and complete onsite inventory management.

Summit uses mobile, ground-level storage containers to meet even your toughest remote onsite needs. They provide the durability and security you expect, while offering the versatility that you require for each job site.

Containers can be configured to your specifications by the available space at each job site, and can be joined together using roll-up doors and docking connections. Their ground-level positioning also offers much faster and more efficient loading and restocking, plus greater safety for job-site crew.

You can choose warehouse units or counter sales units for each job site, or mix and match to create a custom configuration that meets your requirements. Every unit is prewired and includes modular electrical and installed communications. Counter sales units also include HVAC and inventory units have exhaust fans.

Before your SOS facilities ship, they are preconfigured with mounted shelving and can even be preloaded with product, so they arrive on your job site ready to do business. Containers measure 8' x 9'6" x 40'.

Summit can also provide onsite and inventory management services from job-site trailers, cages, cribs, or other warehouse structures, including customer-provided facilities.

Mobile Logistical Units

Warehouse Logistical Unit

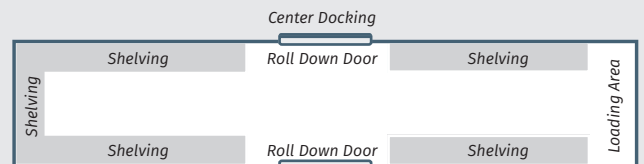

Counter Logistical Unit

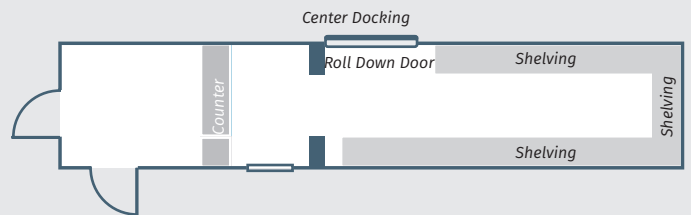

Choose Your Set-Up Option



Option 1

Customer-Managed Onsite Facility

- Your employee mans the onsite facility
- Online set up that allows customer personnel to enter releases directly into Summit's SAP system for real-time inventory management – providing immediate replenishment and eliminating costly delays of manual systems
- Summary billing weekly or as often as you require
- Delivery tickets print with customer bar code
- Your personnel are responsible for receiving materials and providing receiver documents to Summit
- Physical inventory conducted quarterly with monthly Summit visits

Option 2

Summit-Manned OnSite Facility

- Summit OnSite® material manager with extensive product knowledge, employed by Summit
- Summit employee's time charged to you according to existing agreement
- Staff cost determined by pre-negotiated rate
- Material owned and managed by Summit
- Live MRP system in portable storage units
- Real-time inventory management
- Immediate transaction processing
- Onsite purchasing capabilities
- Summary billing weekly or as often as required
- Delivery tickets print with customer bar code for easy entry into your own system
- Daily inventory analysis and replenishment



Inventory Management Solutions

From mobile facilities to various set up options, your complete solution also includes the ability to effectively manage your inventory from your office, your job site or anywhere in between.

Summit's cloud-based inventory management tool brings efficiency and flexibility direct to your projects. Streamlined for accuracy and speed, our system saves you money and time, so you can get on with business.

Using our reliable inventory management tool, you're assured to have the right products when you need them. Place orders, track, and replenish your inventory electronically – all with just a few quick clicks. You'll reduce costs while increasing your profitability and performance, which is just where your bottom line should be.

Summit's inventory tool can be used on any Android or iOS device, making it perfect for use in the field at mobile units, trailers, cribs, and more. A convenient

mobile application allows you to scan bins or items then enter the exact quantities you need. You can also select location-specific products from a list or enter search terms to find a particular item.

Our inventory solution is easy to use and fast to set up. While Summit establishes your location in our system, including your site-specific product catalog and custom bar codes, you just have to download our free inventory management application. Since the app is compatible with any mobile device, you can choose the one that's best for your needs.

We'll show you how to maximize the app's functionality for efficient and effective on-demand inventory replenishment. We can also provide consumption reports that monitor inventory by a number of variables.

Now you can greatly reduce errors and stock outs so your job site operates strong, tough, and fast.

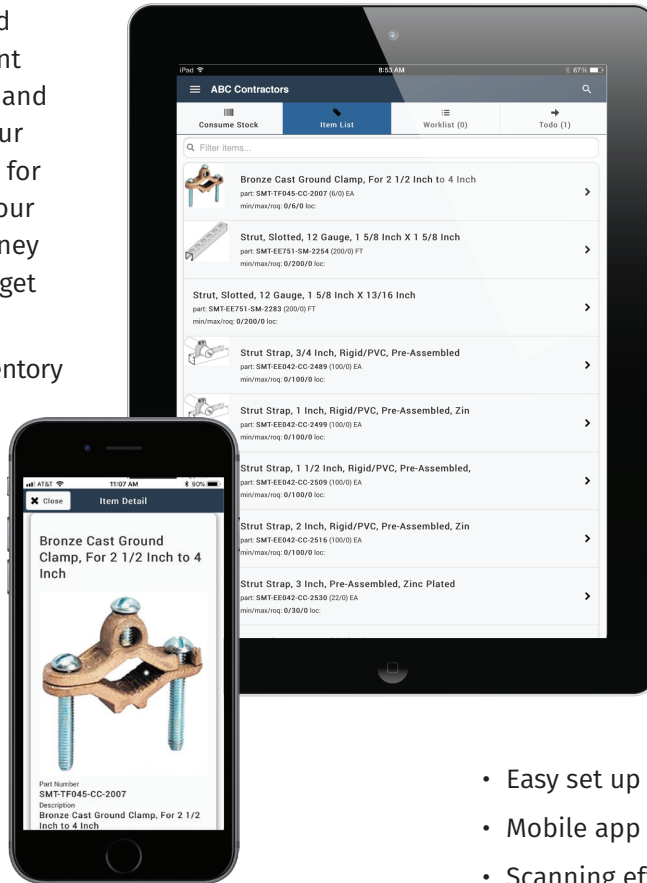

- Easy set up – just download our mobile application
- Mobile app is compatible with any device
- Scanning efficiency eliminates keystroke errors and saves time
- Reduce costs through better inventory management
- Perfect for job trailers, warehouse cribs, and remote sites
- Dedicated sales and support team for your project

Optimized Remote Inventory Management

Plant/Company Code/Plant/Storage Locat...	MRP	Unrestricted use	Sales orders	Schd. for delivery
Total		665.000		665.000
US10 Summit Electric Supply	Z2	665.000		365.000
HOU1		665.000		365.000
0010 ACME Services	Z2	15.000		365.000
0000001113	Z2	150.000		300.000
0000001115	Z2	200.000		300.000
0000001116	Z2	300.000		300.000
0225 ACME Services	Z2	50.000		
0001114	Z2	250.000		

With AMPS®, Summit forecasts inventory requirements by specific location. Each storage location, whether a trailer, cage, or other warehouse space, is set up as a Summit “distribution center” with full SAP functionality. Materials are loaded into a designated SAP account that allows for complete visibility of real-time, on-hand quantities and deliveries.

Customers gain distinctive supply and service advantages by Summit’s ability to replenish the storage locations proactively based on the demands generated on site. The demands are analyzed by Summit’s Material Requirement Planning (MRP) system, which updates every four hours.

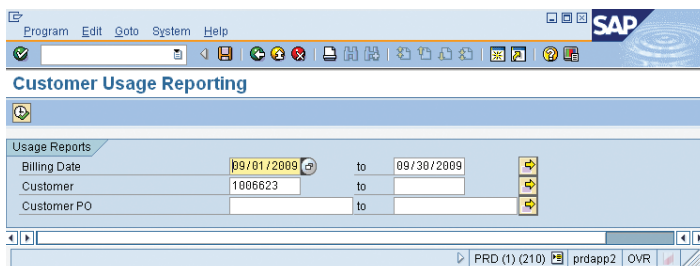

By setting up the storage location as a separate “ship-to” location, reorder points and forecasting parameters can be set so that location’s needs are seen separately from any other. The system also analyzes the number of turns per item and shows slow moving or dead stock.

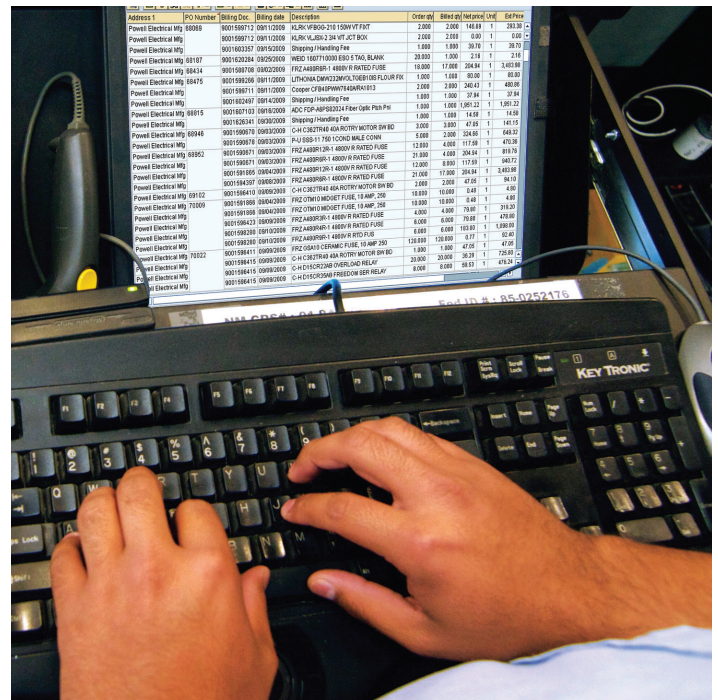

In essence, our inventory management solution allows for real-time monitoring of stock requirements for each managed warehouse space at the individual material level.

The system provides customers with optimal transparency and control over materials.

Wire and Cable Management



Wire and cable management is an important part of any construction project. SAP allows us to track the length of materials on each reel or batch. When an order is entered, the system designates which reel or batch is most efficient to use in filling the order.

As a result, Summit scraps less than one half of 1 percent of our own wire and cable. We can do the same for you.

SAP's robust functionality also allows Summit to track individual circuits down to the specific project installation. After entering circuit ID numbers and descriptions into our system, Summit can match your circuits to our own batch numbers. This gives you detailed order information not just at the material level, but also to related engineer drawings indicating the material's precise implementation.

A Cost-Effective Approach

- Our approach to cable management begins by buying all cable up front, based on your cable schedule. We keep critical runs in stock to eliminate lead-time issues.
- Though cable is purchased in advance of need, you are invoiced only after receiving it for use.
- We do not use a third party for cable management.

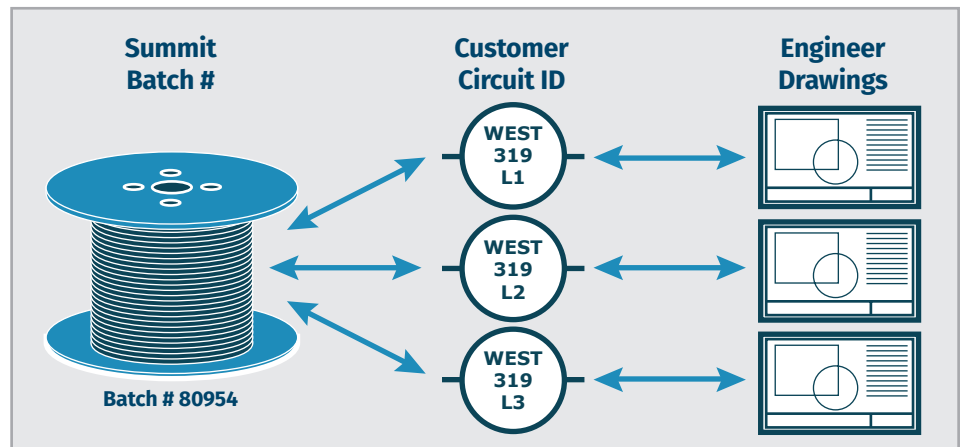

AMPS™ Web Portal on summit.com

Custom web portal for real-time project tracking:

- Customize attributes according to your requirements
- View orders derived from individual drawings
- Monitor pending and completed work packages
- Track order delivery status and documents
- See material-level order information
- Easy filter and sort tools
- Create material releases from one or more drawings (MTOs)
- Route releases for approval
- Submit releases to Summit

The **project screen** displays a list of orders derived from individual drawing numbers.

Static information will appear on every order, every time, including date, order number, drawing number, price, etc. There are up to nine customizable attributes that you can determine. Each static and attribute heading can be sorted simply by clicking on a heading. You may have multiple project screens.

A **drop-down filter** narrows order selections by column headings. Once a heading is selected, you can narrow even further by entering specific filter terms that apply to that heading.

The **order detail screen** displays a material-level view of every item on an order, according to its drawing number.

View detailed delivery information for every order, including delivery date, who received the order, work package number, PO number, etc. Delivery documents are also available. You can choose up to six custom attributes for tracking delivery information.

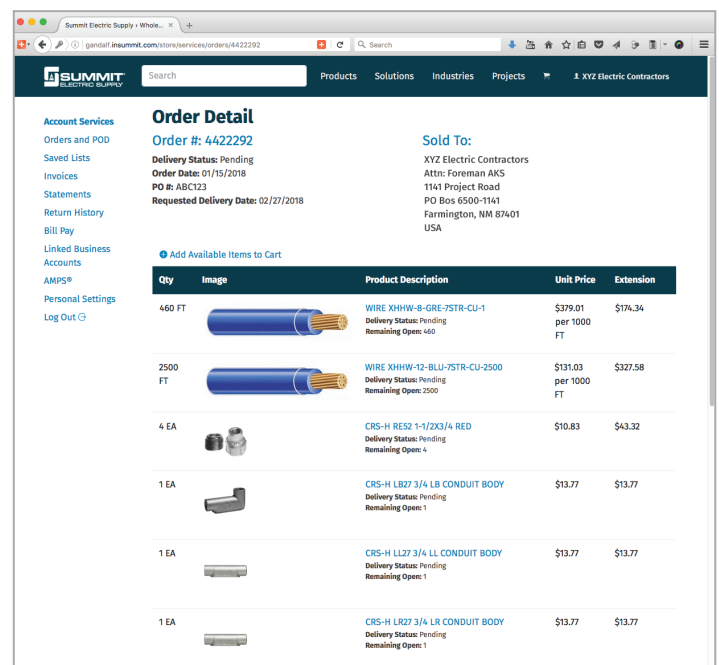
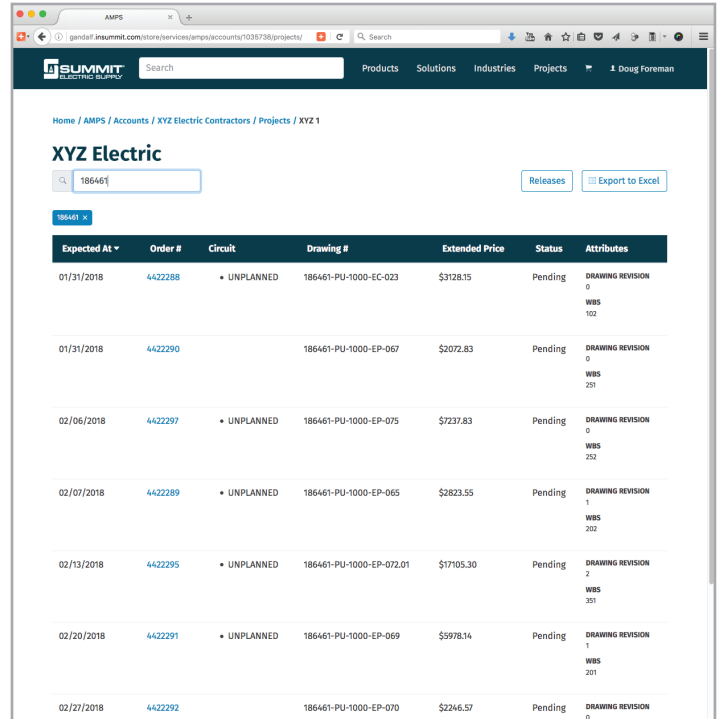

Other Online Services

Powerful Search Functions

Search invoices, return history, orders and POD by PO, invoice number, order number or date range. Search products by manufacturer, UPC, part number or keyword.

Account-Specific Information

Account-specific pricing and real-time availability.

Transaction Tracking and Retrieval

The system helps reduce paperwork and increases efficiency by tracking all transactions online. You can access all orders, invoices, statements and credit memos related to their accounts by date range, purchase order or status. Invoices and statements can be downloaded as PDFs.

Proof of Delivery

Online orders and invoices include proof of delivery/tracking information. If delivered by a Summit truck, invoices also include a scanned image of the signature block from the delivery document.

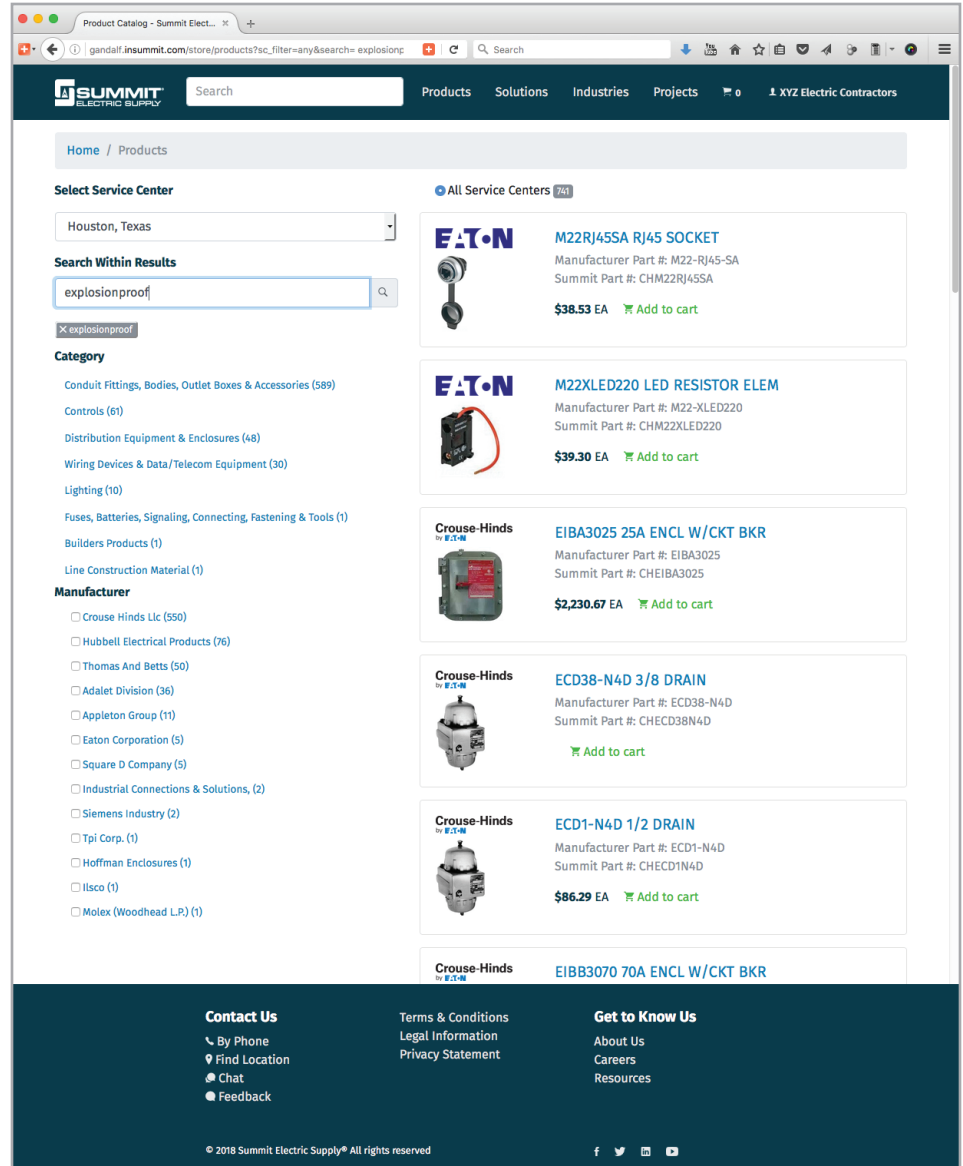

Material Take-Off (MTO) Services



Summit utilizes the services of electrical designers and engineers to perform material take-offs by drawing, detail, and unit or area.

When performing a complete take-off, Summit will generate the material list and guarantee materials and quantities against the drawing. We'll also compare our material lists to yours, then enter all materials into SAP. Once ordered, we'll stage materials for delivery as required.

For detailed drawings, Summit will perform the material take-off and enter materials directly into SAP. Summit's part number for the complete material list will match the detail drawing number.

You can view all materials included in the detail from Summit's online site. Just select the part number to display a drop-down menu of all materials.

Each packing slip will also include a complete list of material with each drawing to assist with checking-in material and verifying required items have been included in the delivery.

Summit's summary billing will only show the drawing number as the part number.



Your Dedicated Summit Team



A dedicated team will be assigned to ensure your success on any project. In addition to a local experienced team, you can be assured of the support at the highest levels of Summit's executive management as well.

Summary

A strategic partnership with Summit Electric Supply offers the technical and logistical capabilities to ensure that the electrical materials so critical to the success of your project will be delivered on schedule - and on budget.

